



Aviation

DACouplings®
Dry Aviation Couplings



FFBall Valves
Full Flow Ball Valves



Aviation
Fuelling Equipment



DDCouplings®
Dry Disconnect Couplings



Swivels
Swivel Joints

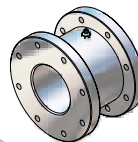

SBCouplings®
Safety Break-away Couplings





DACouplings[®]

Dry Aviation Couplings

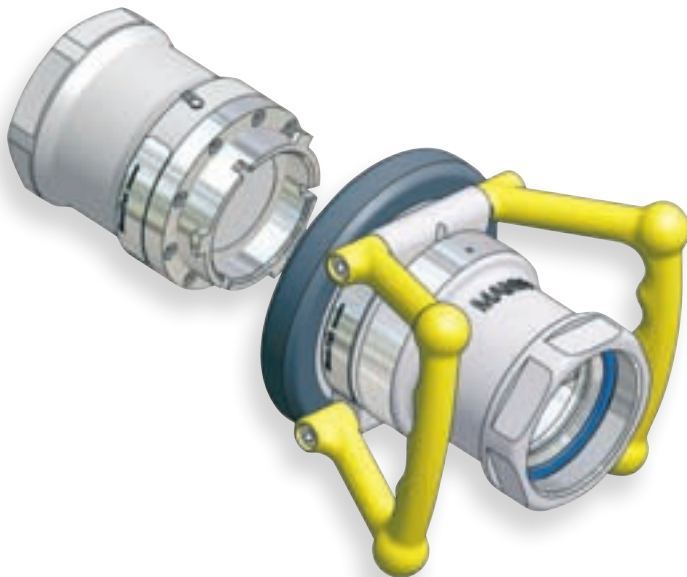

Compatibility

ISO 45, MS24484, NATO STANAG 3105, British Aerospace Specification 2C14

Operation

The DACouplings include a bayonet-type connector and are flanged or threaded to suit installation requirements. Each Tank unit contains a “fail safe” springloaded valve seating on a tapered seat. The valve is controlled by the action of coupling and uncoupling the Hose unit.



The Dry Aviation Couplings are designed for use in aviation and military refueling systems with a maximum working pressure of 10 bar (150 psi). Working temperature range lies within -38°C (-36°F) to +60°C (+140°F), observe that special low temperature seals are used in cold environments. This coupling is not configured for under wing refuelling.

All units can also be used as bottom loading or primary points refuelling vehicles. All units are manufactured to accept the international standard: 2½" the point bayonet, hose end refuelling nozzles, according to: ISO 45 / MS24484 / NATO STANAG 3105 / British Aerospace Specification 2C14.

The couplings consist of high strength Aluminium Body, Coupling ring in Gunmetal and Bayonet flange and inner parts in Stainless Steel and Aluminium. All wetted parts in Aluminium and Stainless Steel.





ISO 45 Dry Aviation Coupling Hose unit with Ground Connection



Why use the Mann Tek Dry Aviation Coupling?

- **Spillfree handling of hoses and loading arms** for loading and unloading tank trucks, rail tankers and tank containers.
- **Minimization of spillage and product loss** keeps the environment free from Hazardous Vapors and Liquids.
- **“Easy to Use”** – design saves time
- **Reliability and easy servicing** saves your investment.
- **ISO 45 2½" is compatible** with existing aviation couplings according to STANAG 3105.
- **Approvals** according to the European Directives PED and ATEX and the international requirements ADR.

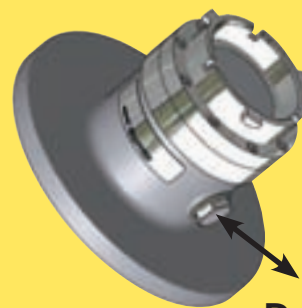

Drain connection

Use Mann-Tek ISO45 with Drain connection for easy draining and sampling of your system.

Selectivity

Selective units are fitted with setting rings.

These have slots cut into them to match up with the corresponding pins on the selective sleeve on the hose unit.

DACouplings[®]

Dry Aviation Couplings

Push and turn

- It's coupled

Fail Safe Design
Double locking device



Anti Clock wise

- It's disconnected

Filter Strainer

The Filter Strainer is designed to adapt on the DACoupling according to the ISO45 standard. The integrated view glass makes it easy to check when the filter has to be cleaned. Easy servicing is guaranteed by a new bayonet connection.

The Filter Strainers are available with 2½" BSP/NPT and 3" BSP/NPT connections.

Sight flow indicator with male BSP thread screws into a ISO 45 Hose Unit with female threads.

There are 3 different filter types, 45 mesh, 60 mesh and 100 mesh.



DDCouplings®

Dry Disconnect Couplings

Mann Tek Dry Disconnect Couplings are used for handling and transfer of liquids, gases and bulk powder in an economical, safe and environmental friendly way.

Dry Disconnect Couplings are available in sizes from ¾" up to 6" and in a wide range of materials and seals to be the given choice for almost any application.

The self sealing design of the couplings guarantees both the highest level of safety and also the quickest way of connecting and disconnecting.



According to NATO STANAG 3756

How it works

The coupling function

The principle of operation is similar for all types of Mann Tek Couplings

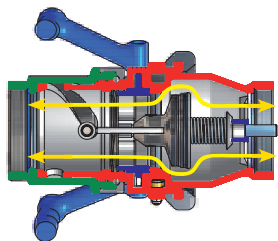

To connect
Push and turn
- it's coupled
- full flow

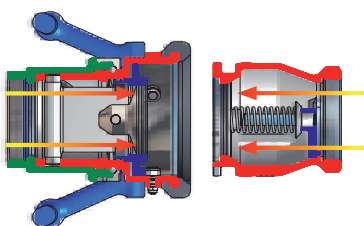

To disconnect
Turn and pull
- it's released
- no spillage

Size:

The couplings are available with BSP- and NPT- threads in sizes ¾" (DN 20) to 6" (DN 150). Other threads are available on request (S60X6, Acme etc.).

The tank units and Hose units are also available in flanged connections (DIN, ANSI, TW, TTMA, EN 1092-1:2001).

Materials:

Aluminium, Brass/Gunmetal, Stainless Steel, Hastelloy C and PEEK. Other materials on request.

Seals:

FPM (Viton®), EPDM, Chemraz®, Kalrez®, NBR (Nitrile). Other materials on request.

Maximum Working pressure:

MWP PN 10 / 16 / 25.

MAWP 150 / 300 psi

Test Pressure:

15 / 24 / 38 bar

225 / 450 psi

Selectivity - Avoid mixing products:

To avoid product contamination caused by connecting a Hose unit to the wrong Tank unit, selective versions of the Hose and Tank units are available. Each unit has a number of selective positions, designated by a coded part number according to the coupling size.

Electrical conductivity

All DDCouplings® have electrical conductivity (<10 ohms).

Interchangeability:

Compatibility with other existing brands according to NATO STANAG 3756 and ATOFINA SGM 2049.TUY.C.

Special models:

With integrated break-away, pressure relief valve, etc. on request.





Advantages DDCouplings

- **Easy to handle**
Push and turn - free flow.
Turn and pull - closed.
- **Time saving**
No need to drain hoses or pipe systems.
- **Economical**
No loss or spillage of liquids at connection or disconnection.
- **Safe**
The valve cannot be opened until the unit is coupled.
- **Environmentally friendly**
Accidental spillage eliminated.
- **Reliability**
No loss or spillage of liquids at connection or disconnection.

Anti-icing and De-icing



Anti-icing

Anti-icing is the process of protecting against the formation of frozen contaminant, ice, snow and slush of an aircraft.

De-icing

De-icing is the process of removing frozen contaminant, ice, snow and slush from an aircraft.

When there are freezing conditions and precipitation, de-icing an aircraft is crucial.

De-icing on the ground is usually done by spraying aircraft with a de-icing fluid such as propylene glycol, similar to ethylene glycol antifreeze used in some automobile engine coolants. Ethylene Glycol (EG) is still in use for aircraft de-icing in some parts of the world because it has a lower operational use temperature (LOUT) than PG and is more versatile in application, but Propylene Glycol (PG) is more common because it is classified as non-toxic, unlike Ethylene Glycol.

Dry Disconnect Couplings

2" (70 mm), 2,5" (105 mm) and 3" (119 mm)
Dry Disconnect Couplings used in Anti-icing and De-icing systems.



Aviation

Fuelling Equipment

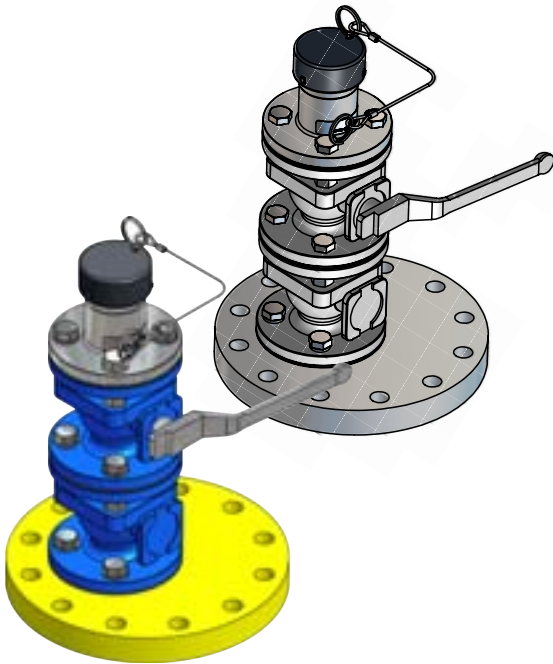

Why use the Mann Tek Sampling, Vent or Drain Units?

- Take a sample to check the quality of fuel in a hydrant system on airports.
- Draining of condensate and venting out of hydrant systems.
- Preventing pressure drop while sampling by sluice valves with fire safe function.
- Fits into standard 18" external pipe pits with ANSI 6" 300 psi flange.
- "Easy to Use" – design saves time and minimizes health risks.
- Reliability and easy servicing saves your investment.
Approved for safe handling by independent
○ "Notified Body".
- Connection by 70 mm dry disconnect coupling acc to STANAG 3756.
- Dry disconnect coupling equipped with built in Pressure Relief and Bleeding Valve function.





Application

Sampling - installed at a convenient point on a riser from the main hydrant line

Venting - installed at a high point in the hydrant line

Draining - installed at a low point in the hydrant line

Modern airports are using an underground pipeline, for the fuelling of aircrafts. Mobile dispensers are the interface between this hydrant system and the airplane.

They are containing pumps, valves, hoses and couplings to pump the fuel from the hydrant system to the plane.

The pipelines are designed with high points, low points and convenient points. If there is condensate in the pipeline, which is heavier than the fuel, it will sink to the low points.

Encapsulated air will rise to the high points. Neither water nor air is very welcome in the pipeline.

To get them out of the pipeline there are sampling units at each low point for draining and at each high point for venting.

At the convenient point the sampling units are used to take samples of the fuel to check the quality.

FFBall Valves

Full Flow Ball Valves



Sizes

2" (DN 50) to 4" (DN 100)

Connections:

Full Flow ball Valves and 2-way Ball Valves are available with BSP- and NPT-threads and with flanges (DIN, ANSI, TW, TTMA, EN 1092-1:2001).

Maximum Working Pressure:

MWP PN 10
MAWP 150 psi

Material:

Body: Aluminium
Ball: Aluminium
Spindle: Stainless Steel

Seals:

Teflon® (PTFE), Viton® (FPM).
Other Seals on request.

Advantages

- Unflattened flanges do not affect the balls torque.
- All wetted parts in: Aluminium, Stainless Steel, FPM (Viton®), PTFE (Teflon®). No Yellow parts.
- The sealing stays in its position also when you are regulating high flowrates.
- Low pressure drop.
- Easy to serve: The spindle can easily be dis-mounted, even if the ball valve is installed.
- The valve is assembled as one unit - not kept together by the flanges.
- Inbuilt measurements as common standard.

Applications

- Petroleum Tank trucks
- Tank trucks for solvents
- Dispenser and Tank trucks for aircraft refueling
- Stationary and mobil equipment for aircraft refuelling
- Loading Aviation refueller



SBCouplings[®]

Safety Break-away Couplings



Sizes

1" (DN25) to 12" (DN150)

Maximum Working pressure:

MWP PN 10 / 16 / 25.

MAWP 150 / 300 psi

Test Pressure:

15 / 24 / 38 bar

225 / 450 psi

Materials

Aluminium, Brass, Stainless steel, Hastelloy, Titanium. Others on request.

Connections

Female and Male BSP / NPT, flanges DIN and ANSI. Others on request.

Industrial Break-away

Typically installed into loading arm and hose assemblies, where at least one side of the coupling is attached to a rig and fixed point.

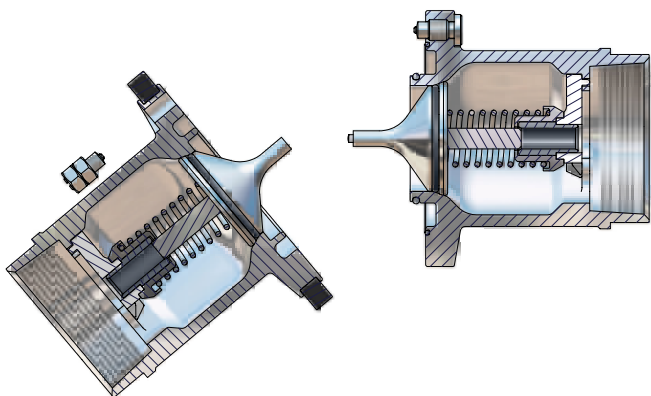

Release with a tensile force being applied at an angle to the plane of the coupling housing, up to 90 degrees.

Safety Break-away couplings are used to prevent pull away accidents, the internal valves will close the flow in both lines and prevent unwanted release of product.

The Safety Break-away couplings are available as Industrial and Marine type.

Industrial Break-aways are used at fix points like manifolds, pipelines depots etc.

The Safety Break-away couplings are used in filling systems for airfields, rail tank cars, tank containers etc.

Industrial Break-away coupling is utilized all industrial product transfer installations.

The industrial SBCouplings are specifically designed to be able to activate with a tensile force being applied at an angle to the plane of the coupling housing, up to 90 degrees.

Features

- Passive security against situations where a hose or loading arm could be subjected to inadvertent excessive loads.
- Design features are a simple mechanism and no loose components which could be lost after release.
- Operates independently of shut off safety system and does not require an external power source.
- Easy to reset on site with one person
- High flowrate / low pressure drop
- Very low loss, positive shut-off of both coupling halves results in minimum product loss.
- Lightweight and robust design.
- Available with ANSI/DIN flanges or threaded (BSP or NPT).

Swivels

Swivel Joints

Hose swivels



Sizes

¾" (DN20) to 4" (DN100)

Maximum Working pressure:

MWP PN 10 / 16 / 25.

MAWP 150 / 300 psi

Test Pressure:

15 / 24 / 38 bar

225 / 450 psi

Materials

Aluminium, Brass, Stainless steel,
Hastelloy, Titanium. Others on request.

Connections

Female and Male BSP / NPT, ACME, Witworth threads and flanged DIN and ANSI. Others on request.

NOTE

*Unsuitable for high bending moments.
Heavy Duty Swivels should be used in
these applications.*

Heavy Duty Swivels - double ball race

Sizes

1½" (DN40) to 10" (DN250)

Materials

Stainless Steel.

Other material on request.

Maximum Working pressure:

MWP PN 10 / 16 / 25 / 40

MAWP 150 / 300 / 600 psi

Connections

Female and Male BSP / NPT, ACME, Witworth threads and flanged DIN and ANSI.

Others on request.



Mann Tek Swivels

The use of swivel hose avoids torsion of hose assemblies, i.e. in filling machines, and improves the handling and coupling of nozzles for refuelling of petroleum based products and chemicals.

Features

- ▶ **Simple design, low maintenance.** Each unit consists of two body halves. Stainless Steel balls and a single spring assisted O-ring seal.
- ▶ **Compact external dimensions**
- ▶ **High flow rate / low pressure drop**
- ▶ **Full range of sizes, materials, seals and connections**
- ▶ **Minimal maintenance requirements**
- ▶ **Safety Swivel function** - allows the hose to relax to its natural rest position whilst allowing freedom of movement without imparting torque stress at the point of connection - Torque stress is the largest single cause of Composite, PTFE and Stainless Steel convoluted hose failure.
- ▶ **Economical** Cost effective solution to prolong lifetime of hoses.





Mann Tek couplings for military use.

The DDCcoupling and DACouplings, in green colour, are also used for Military purposes with different adaptor systems.



Connection adaptor:

- 2½" ISO45 to 3" (119 mm) Tank Unit STANAG 3756.
- 2½" ISO45 to 3" (119 mm) TW EN14420-5
- 3" (119 mm) Hose Unit / Tank Unit STANAG 3756 to 3" (119 mm) TW EN14420- 5 Hose Unit / Tank Unit
- 3" (119 mm) Tank Unit STANAG 3756 to 2½" (105 mm) Hose Unit



2½" ISO45 Hose Unit to Tank Unit
3" (119 mm)¹⁾ STANAG 3756



3" (119 mm)¹⁾ Tank Unit STANAG
3756 to 2½" (105 mm)¹⁾ Hose unit

The ISO45 Tank Unit are also available with **pressure equalizing valve** and **pressure relief valve**.

Fluids / Military fuel:

F34 (JP8) AVTUR/FSII fuel
(UN No 1223 (Inst Pet Class 2))

F35 (Jet A1) AVTUR fuel
(UN No 1223 (Inst Pet Class 2))

F44 (JP5) AVCAT/FSII fuel
(UN No 1223) Inst Pet Class 3))

F54 DIESO fuel
(UN No 1202 (Inst Pet Class 3))

F65 DIESO fuel

F67 Benzin

About Mann Tek

Mann Teknik AB is a Swedish company located in Mariestad, Sweden.

Mann Teknik AB designs, manufactures and markets products for safe and environmentally friendly handling of aggressive fluids for the chemical and petrochemical industries.

The main product is the Dry Disconnect Couplings, DDCouplings®, for spill free liquid handling. The products are marketed through independent representatives in more than 30 countries.



Company Approvals

Mann Teknik AB are certified to ISO9001:2008. The products are CE-labeled. The main products are certified to PED, the European Pressure Equipment Directive and ATEX, the European directive for Equipment intended for use in Potentially Explosive Atmospheres.

The products are produced in accordance with several important standards, e.g. the NATO STANAG 3756



KilltheSpill

Product and company information

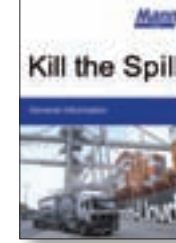
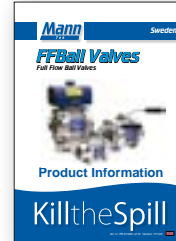
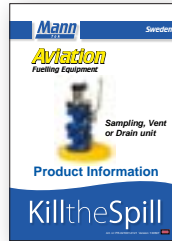

Approvals

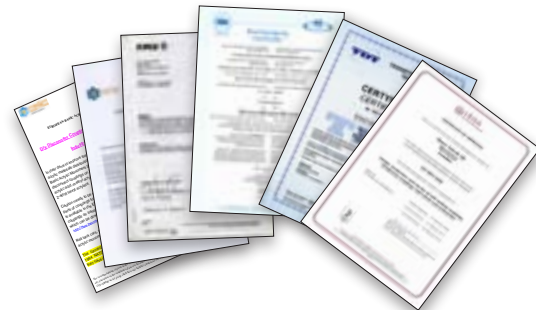

ISO 9001, PED 97/23/EC , TDT, TÜV, Apragaz, FMV, Gost, ATEX e.t.c

Contact Mann Tek

Phone: +46 501 39 32 00
Fax: +46 501 39 32 09
Email: sales@mann-tek.com
Web site: www.mann-tek.com
Address: Mann Teknik AB
Strandvägen 16
S-542 31 Mariestad
Sweden



Mann-Tek is a certified ISO9001-company.